

Pre-Filter

High Flow Automatic Screen Filter

APPLICATIONS

The HRV Pre-Filter is intended for use on municipal potable water (mains) to remove fine sand, sediment and rust particles from 70µm upwards in size.

GENERAL INFO

Designed to clean all water coming into the home protecting; taps, shower heads and all water using appliances.

FEATURES | BENEFITS

◆ SELF CLEANING

Built-in digital timer automatically starts the back flushing process at pre-set time.

◆ CLEAR FILTER HOUSING

Easy monitoring of water quality by looking at dirt accumulated on strainer.

◆ LARGE LCD DISPLAY

Dual-button interface for easy setting and operation.

◆ BACKUP BATTERY POWER

Automatically activates when the normal power supply is interrupted.

◆ Stainless Steel filter screen

◆ Polypropylene filter head with LCD screen for automatic pre-filter

◆ Includes quick connect attachment to plumbing



WAT FILT PHSF-A

Pre-Filter

High Flow Automatic Screen Filter

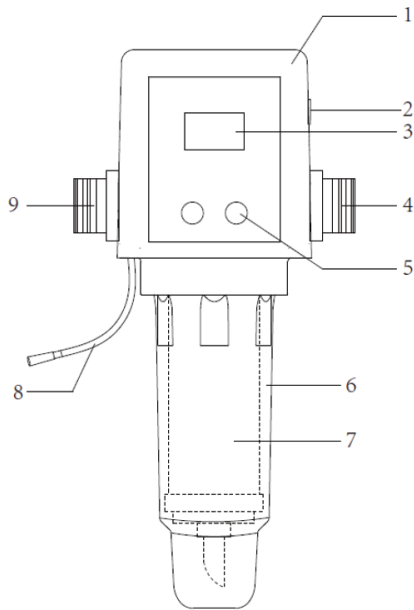

1. Top Cover (filter head inside)
2. Drain
3. Display Window
4. Water Outlet
5. Button
6. Clear sump
7. Stainless Steel filter net
Polypropylene support filter core
8. Power cord
9. Water Inlet

SPECIFICATIONS

Inlet & Outlet
3/4" NPT Thread

Operating Pressure
15-60psi

Maximum Flow Rate
4000 litres (4 m³/h)

Maximum Capacity*
15 million litres (15000m³)

Control Method
Automatic

Power Requirement
220V/50Hz or 4 AA Batteries

Water Temperature
5-38°C

Filtration Accuracy
70-90 microns

Filter Cartridge Lifespan
5 Years

* Backflushing is required after every
50,000 litres (50m³)